

access

L I G H T I N G

INSTALLATION INSTRUCTIONS

IMPORTANT

Before assembling your access lighting fixture, please make sure that you carefully read through these instruction sheets. Consider having your fixture installed by a qualified licensed electrician.

NOTE: The important safeguards and instructions that appear in this manual are not meant to cover all possible conditions and situations that may occur. It must be understood that common sense, caution and care, are factors that can't be built into any product. These factors must be supplied by the person(s) caring for and operating the fixture.

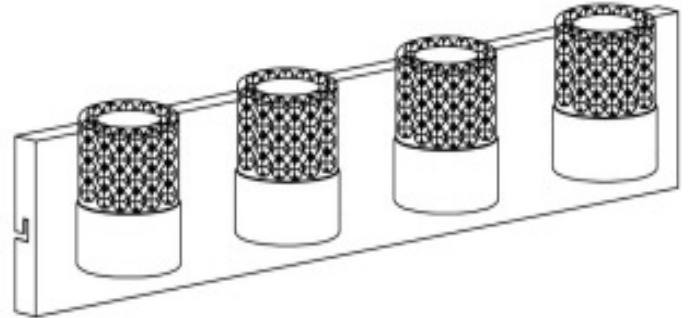

GENERAL INFORMATION

All electrical connections must be in accordance with all ordinances, Local and National Electrical Codes. These fixtures are intended for mounting to a standard 4" x 2 1/2" metal octagon outlet box. The box must be directly supported by the building structure and U.L. Recognized.

STEP BY STEP INSTRUCTIONS

Before starting your installation disconnect the Power by turning off the Circuit Breaker or by removing the fuse at the fuse box. Just turning the light off at the light switch is not sufficient to prevent electrical shock.



COLLECTION

APPLICATION

Wall Fixture

MODEL NO.

51014

WHAT WE PROVIDE

- Crossbar
- Mounting Hardware
- Canopy with Fixture
- 4 x Glass Shades
- 4 x GU9 Bulbs

WHAT YOU NEED

- Screwdriver
- Wire Cutters
- Wiring Supplies as Specified by Electrical Code

MOUNT CROSSBAR

1

If there is an existing fixture remove it. Hold the fixture up to the j-box, mark the location on the wall for the additional supports. Drill holes and insert the supplied wall anchors. Expose the supply wire from the outlet box, pulling them through the center hole in the crossbar. Mount the crossbar to the junction box with the supplied screws. Insert the additional screws into the anchors.

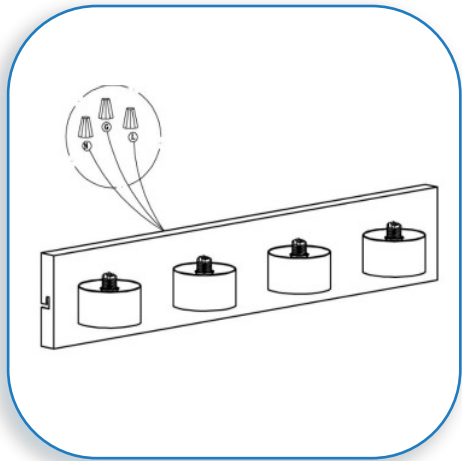

2

CONNECT THE WIRES

Gently pull the supply wires. Connect the black supply wire to the black fixture wire. Secure with the supplied wire nuts. Connect the white supply wires to the white fixture wire. Secure with the supplied wire nuts. Either wrap the green wire around one of the protruding screws or connect it to the supply ground wire. Secure all wire with electrical tape (not supplied).

Tuck all wires carefully into the J-Box.

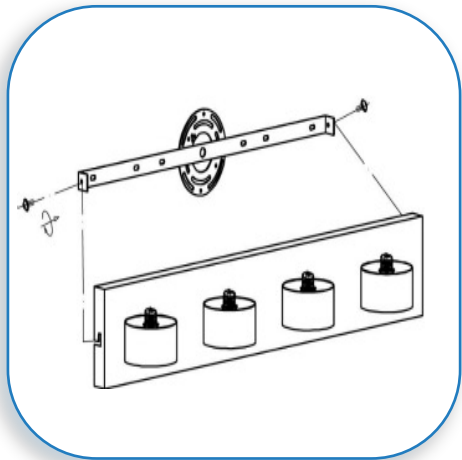

3

MOUNT THE CANOPY

Fit the fixture canopy over the protruding u-shaped arms on the crossbar. Align the screw holes on the sides of the u-shaped arms with the holes in the canopy. Insert the supplied screws, tighten down and adjust the canopy so that the screw is secured in the I-shaped key lock. Tighten down.

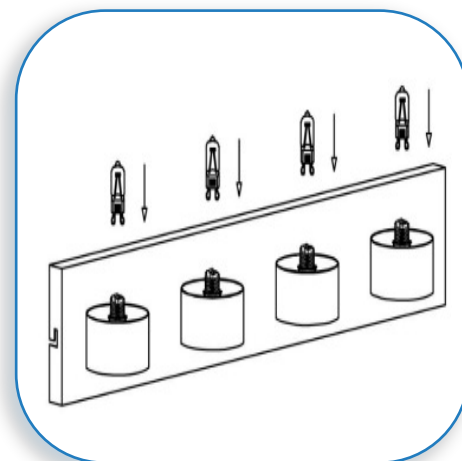

4

INSERT THE BULBS

Insert the supplied bulbs. Do not handle the bulbs with your bare hands, but use the supplied sponge cloth. **MAXIMUM WATTAGE 40W..**

DO NOT EXCEED THE RECOMMENDED WATTAGE AS STATED ON THE WARNING LABEL.



5

SECURE THE GLASS SHADES

Secure the glass shades to the fixture, by fitting the glass over the socket. Sit the glass flush on the metal area surrounding the socket. Secure the glass with the supplied glass retaining ring tool, by screwing it onto the threaded portion of the socket.

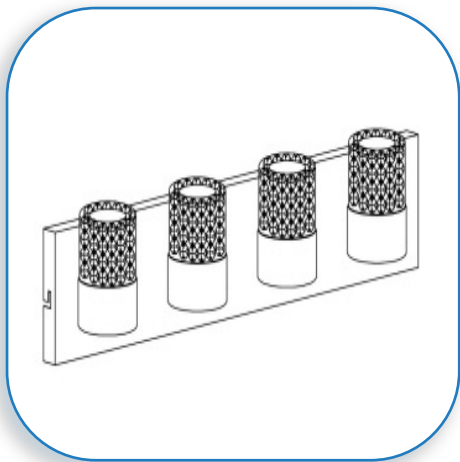

6

RESTORE THE ELECTRICITY AND CHECK THE OPERATION OF YOUR NEW ACCESS FIXTURE

CAUTION Please ensure that the fitting is cool and switched off before replacing the bulb. DO NOT use bulbs that might exceed the maximum wattage, stated on caution label.