

Assembly Instructions For

WB1376 (E) 5/29/09

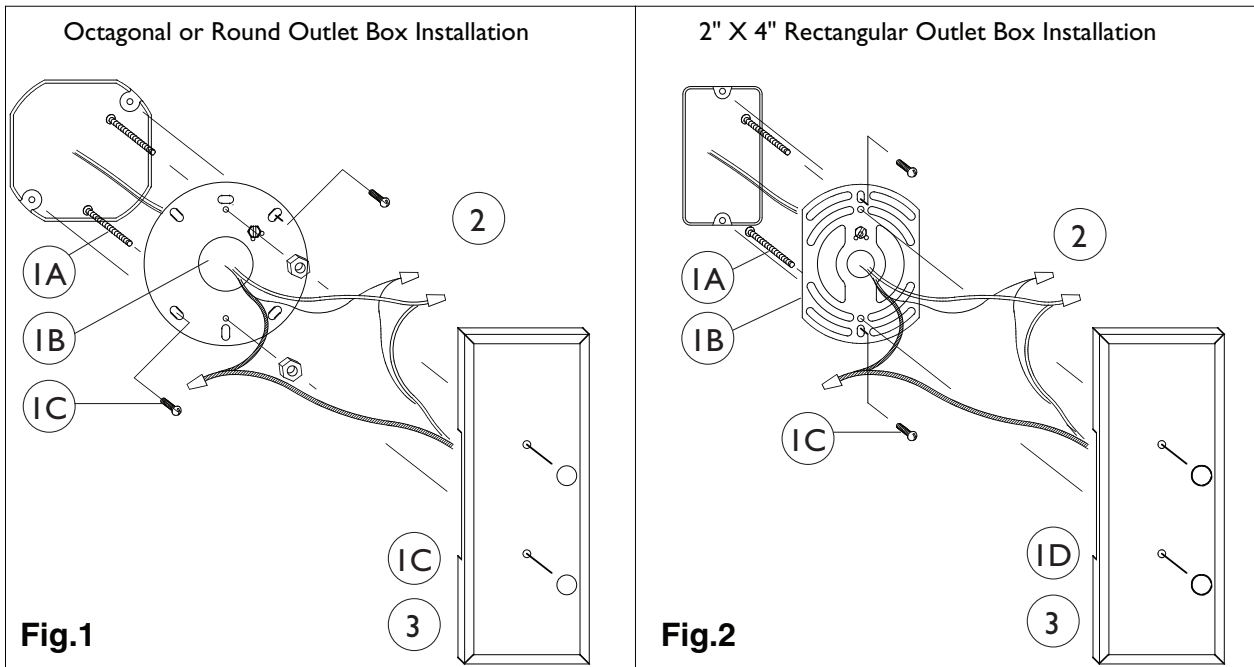
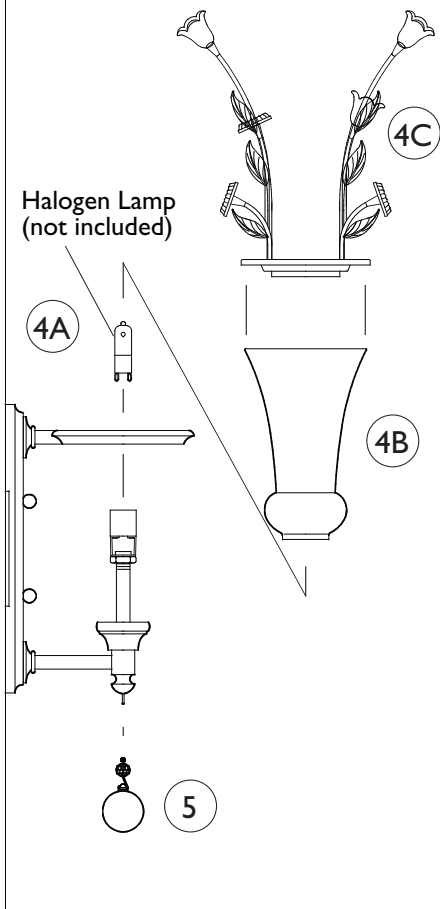

Fig.1

Fig.2



IMPORTANT
TURN OFF THE POWER AT THE MAIN FUSE OR CIRCUIT BREAKER BOX
BEFORE STARTING INSTALLATION

Carefully unpack and identify all parts before assembly. Bulbs not included.

1. This fixture can accommodate two types of wall outlet boxes: A. Octagonal or round B. 2 x 4 rectangular

OCTAGONAL OR ROUND OUTLET BOX – Use round mounting plate (supplied) See fig. 1.

- A. Fasten two long machine screws (supplied) onto the mounting plate (from the side opposite of green grounding screw head). NOTE: Install onto holes corresponding with fixture plate mounting holes.
- B. Take supply wires from outlet box and carefully pass them through center hole of mounting plate.
- C. Install mounting plate onto the outlet box using two screws supplied with outlet box.
- D. Test install fixture plate to make certain about 1/4" (5mm) of screws thread protrude outside of fixture plate. If not then remove fixture plate and adjust screws length accordingly. Secure screws length by fastening with two hex nuts. Make certain not to spin screws during fastening. Place fixture plate aside.
- E. Spread electrical wires so that black wires are on one side of the outlet box and the white wires are on the other side.

2 x 4 RECTANGULAR OUTLET BOX – Use semi round mounting plate (supplied) See fig. 2.

- A. Fasten two long machine screws (supplied) onto the mounting plate (from the side opposite of green grounding screw head). NOTE: Install onto holes corresponding with fixture plate mounting holes.
- B. Take supply wires from outlet box and carefully pass them through center hole of mounting plate.
- C. Install mounting plate onto the outlet box using two screws supplied with outlet box.
- D. Test install fixture plate to make certain about 1/4" (5mm) of screws thread protrude outside of fixture plate. If not then remove fixture plate and adjust screws length accordingly. Place fixture plate aside.
- E. Spread electrical wires so that black wires are on one side of the outlet box and the white wires are on the other side.

2. Connect electrical wires:

- A. Connect white fixture wire(s) to white supply wire from outlet box with wire connector. Connect black fixture wire(s) to black supply wire from outlet box with wire connector. NOTE: Black outlet box wire may be red, round and smooth and/or have copper conductor. White outlet box wire may be square and ridged and/or have a silver conductor.
 - B. Connect fixture ground wire (without plastic insulation) to ground wire from outlet box (usually with green insulation) with wire connector.
- Note: If there is no supply ground wire at outlet box then attach fixture ground wire securely onto green grounding screw located at mounting plate.
IMPORTANT: Never connect ground wire to black or white supply wires (from outlet box).

3. Install fixture plate. While carefully tucking all electrical wires inside of fixture plate, install the fixture plate onto the mounting plate by fastening with two cap nuts.

4. A. Install G9 base of 75 Watt maximum halogen lamp (not included).
 B. Install glass vase by slipping inside of center ring
 C. Install flower assembly by sitting on top of center ring.

5. Hang crystal at bottom of fixture.



MURRAY
FEISS
 Generation Brands™